



**SUBARU**

PART NUMBER: D441SVA000

INSTALLATION  
INSTRUCTIONS

DESCRIPTION:  
STI PERFORMANCE EXHAUST  
WRX STI

A

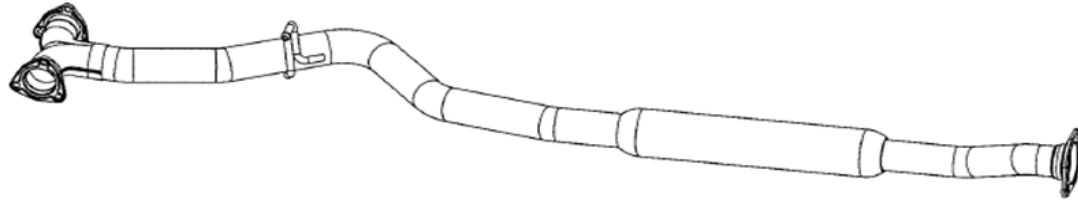

REAR EXHAUST PIPE

B

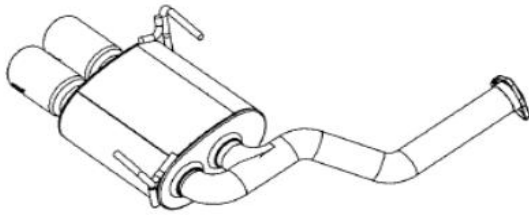

RH MUFFLER

C

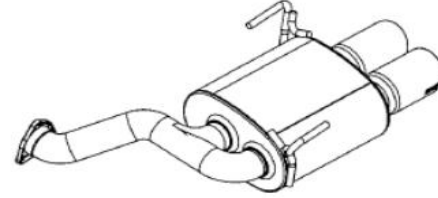

LH MUFFLER

D



DONUT GASKET

E



MUFFLER GASKET

F

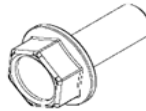

BOLT

G

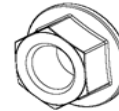

LOCKING NUT

H



DISCLAIMER/CARE SHEET

**HARDWARE KIT P/N D441SVA040: CONTAINS ITEMS D,E,F,G,H**

**TOOLS REQUIRED:**

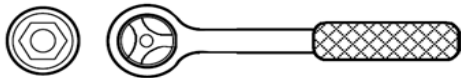

14mm & 12mm DEEP SOCKET AND RATCHET



TORQUE WRENCH



EXTENSION



14mm & 12mm WRENCH

PART NUMBER:  
D441SVA000

ISSUE  
01

1/28/2014

SUBARU OF AMERICA

PAGE  
1/8



MEANING OF CHARACTERS

: Remove

**T** : Tighten Torque

: Install

: Loosen

: Disconnect

: Discard

: Connect

: Location of Clip or Screw

: Re use

: **Manual Process**

TOOLS			LOCATION			WRX STI
-------	--	--	----------	--	--	---------

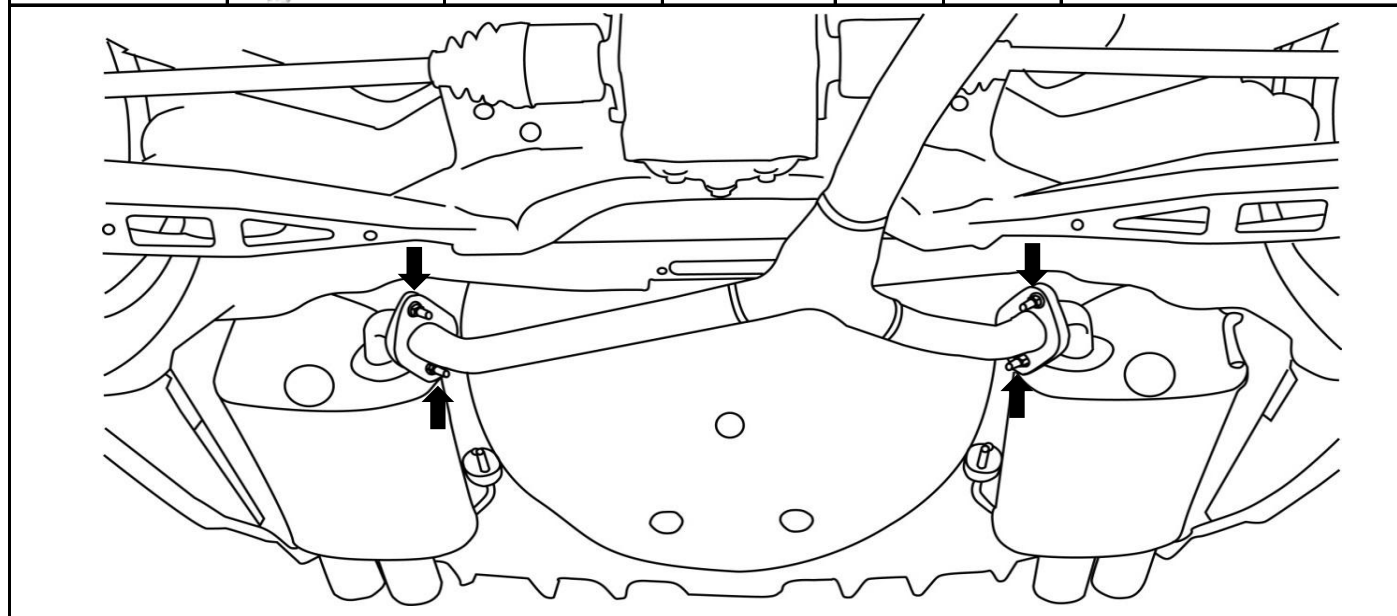



- 1: Lift up the vehicle. CAUTION: Vehicle components are extremely hot after driving. Do not touch any component until the vehicle has cooled down.
- 2: Remove and discard the nuts and bolts connecting the rear exhaust pipe to the mufflers.

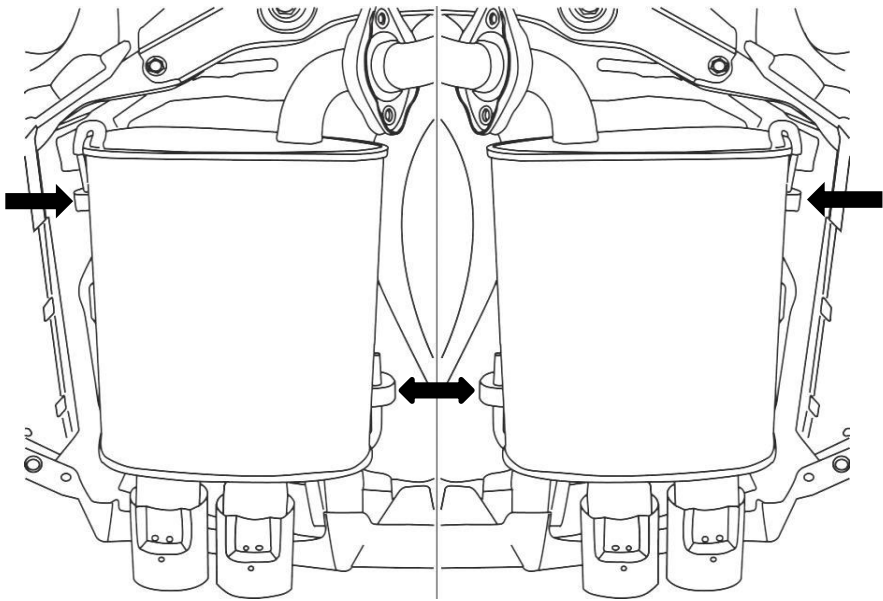

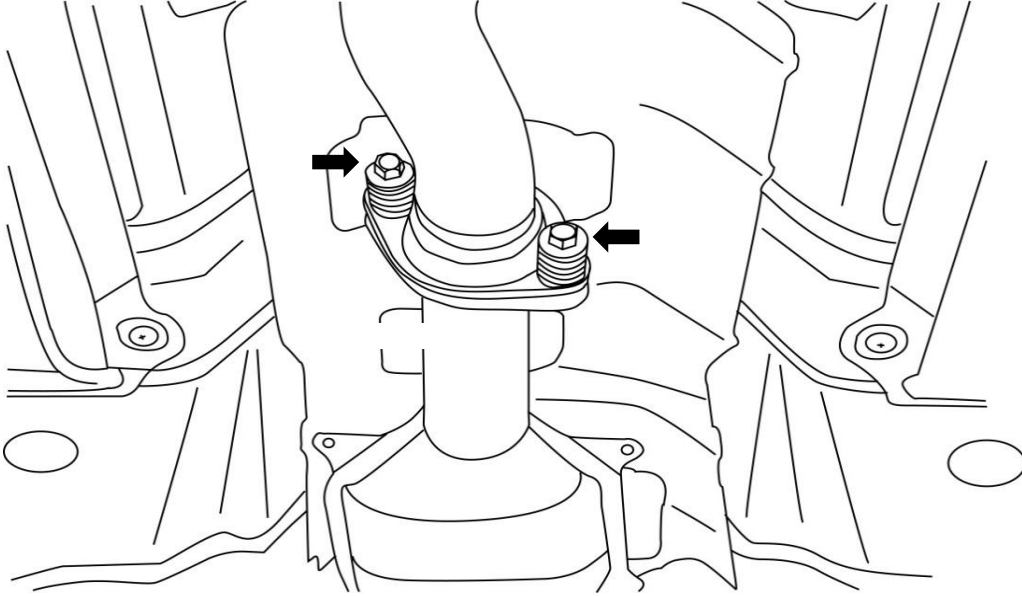

TOOLS			LOCATION			WRX STI
						
<p>3: Apply a coat of spray type lubricant to the mating area of the rubber exhaust hangers.            4: Remove the mufflers from the rubber exhaust hangers. CAUTION: Be careful not to drop the mufflers during removal.</p>						

TOOLS	 14mm	 12mm	LOCATION				WRX STI
							
<p>5: Remove and retain the bolts, springs and nuts from rear exhaust pipe and separate it from the catalytic converter tube. Discard the donut gasket.  <b>DO NOT REUSE THE DONUT GASKET.</b></p>							

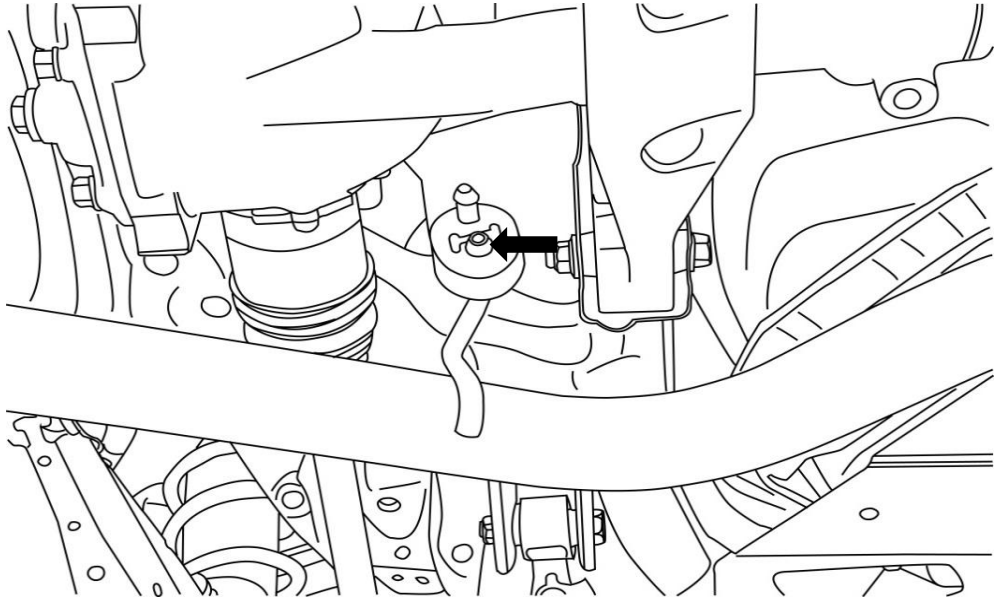

TOOLS			LOCATION			WRX STI
						
<p>6: Apply a coat of spray type lubricant to the mating area of the rubber exhaust hanger. 7: Remove the rear exhaust pipe from the rubber exhaust hanger. CAUTION: Be careful not to drop the rear exhaust pipe during removal.</p>						

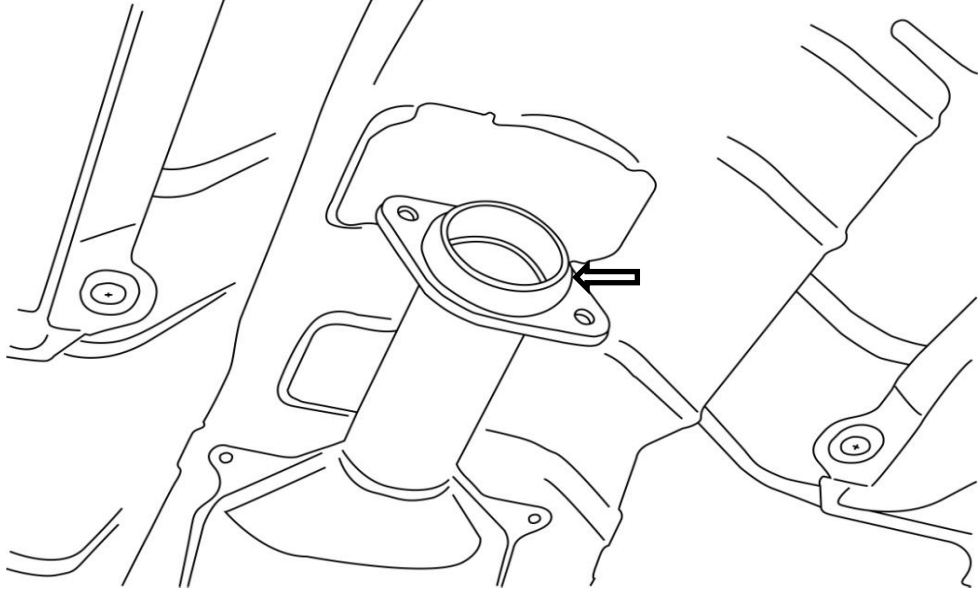
TOOLS			LOCATION			WRX STI
						
<p>8: Install the new donut gasket (D) onto catalytic convertor tube.</p>						

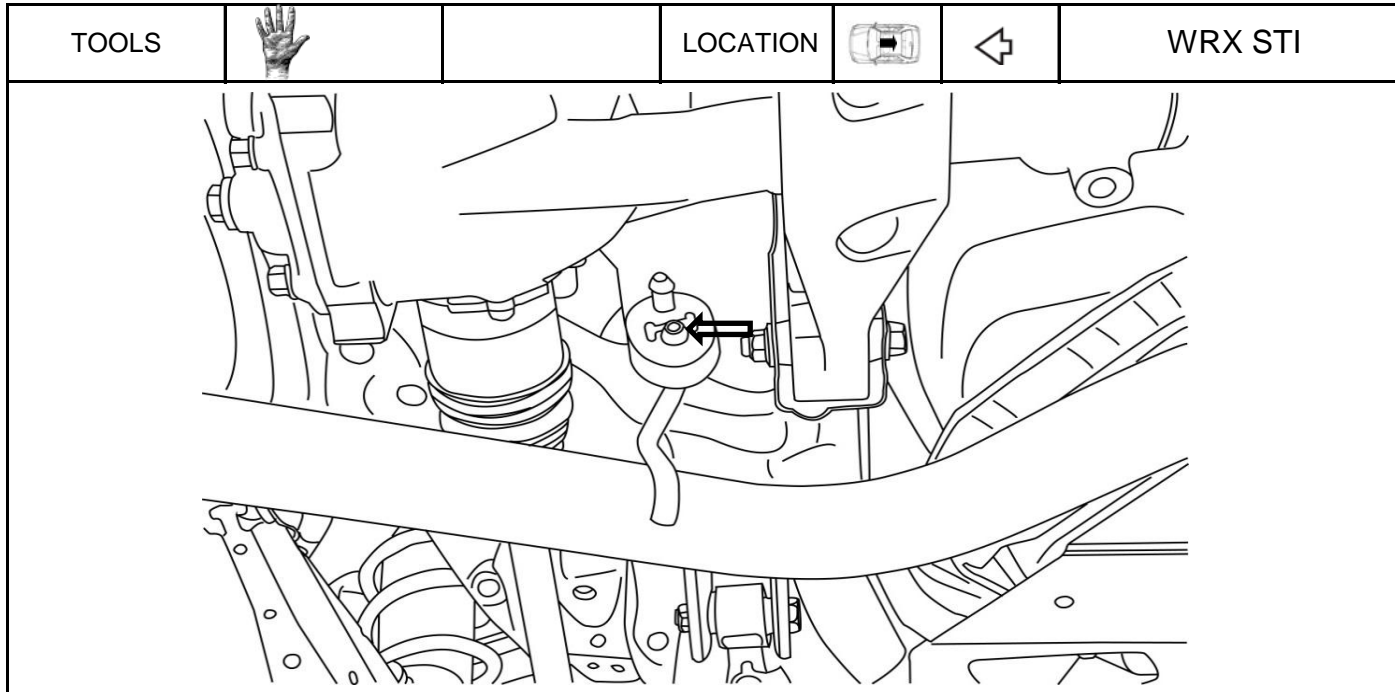

9: Install the new rear exhaust pipe (A) into the rubber exhaust hanger.  
 10: Degrease the lubricant which was applied to the rubber exhaust hanger while removing/installing.

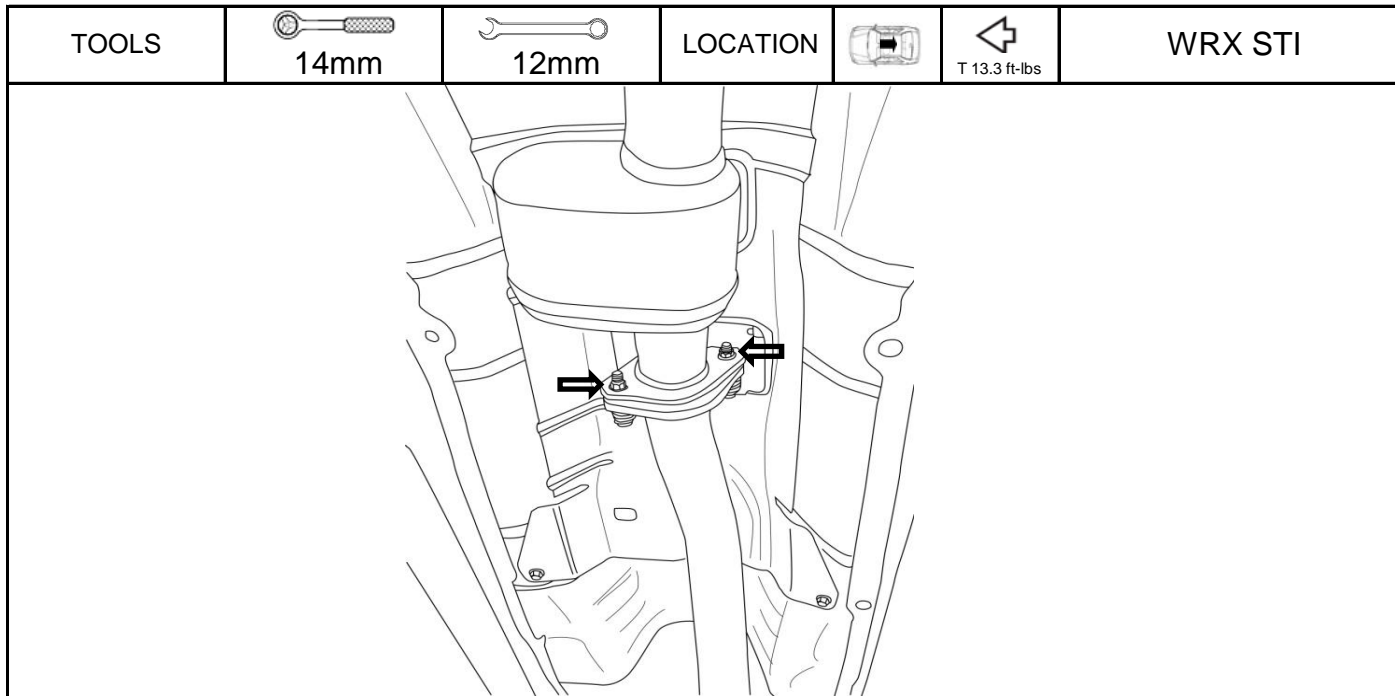

11: Connect the new rear exhaust pipe (A) to the catalytic converter tube with the bolts, springs and nuts removed in step 5. Torque nuts to 13.3 ft-lbs (18 N·m).

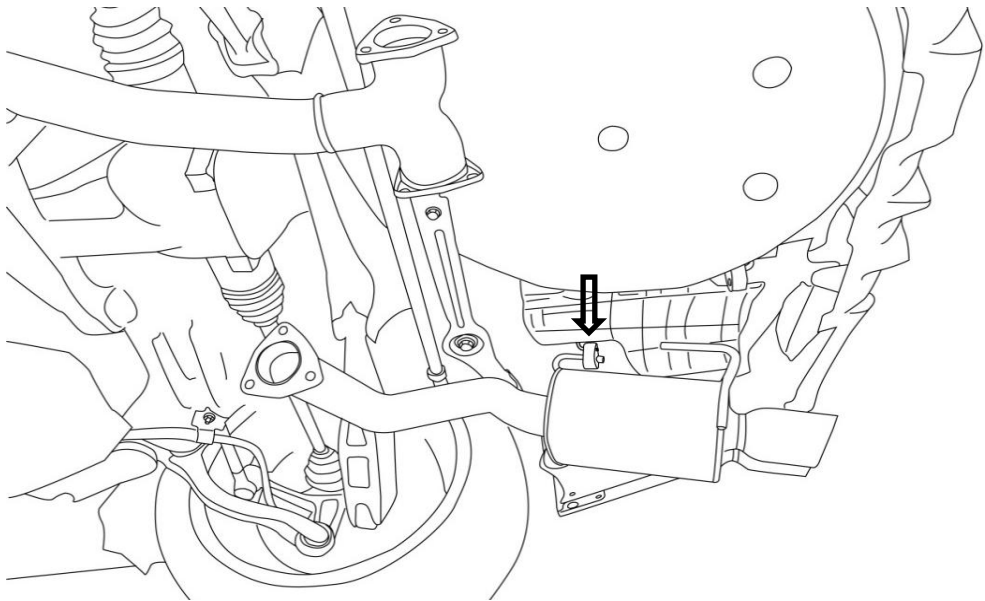

TOOLS			LOCATION			WRX STI
						
<p>12: Hang the new muffler (B) on the outside exhaust hanger.</p>						

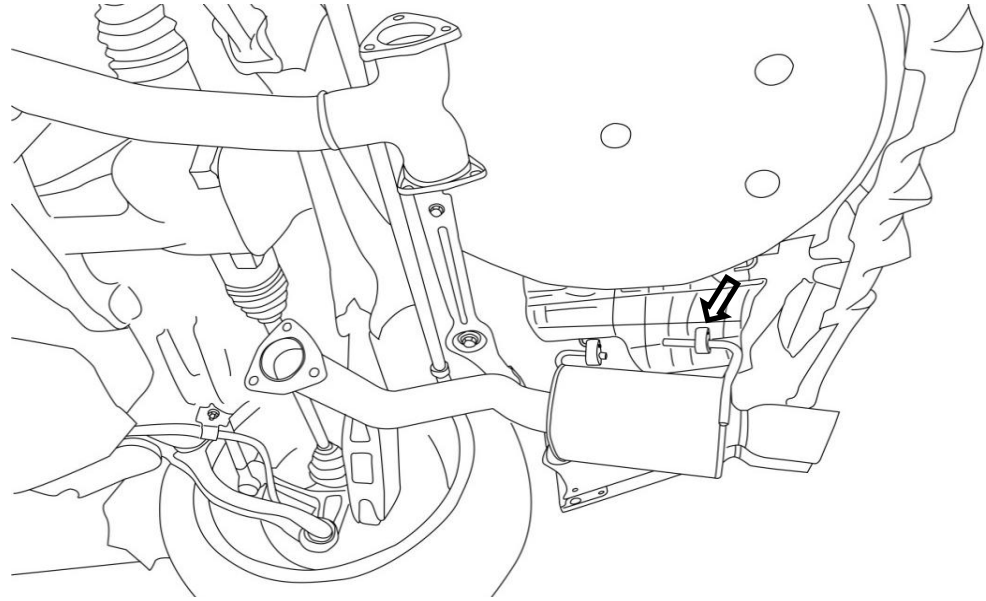
TOOLS			LOCATION			WRX STI
						
<p>13: Transfer the inside exhaust hanger from the vehicle onto the muffler. Then hang exhaust hanger muffler assembly back onto the vehicle. 14: RH muffler shown, repeat step 12 and 13 for LH muffler.</p>						



TOOLS	14mm	14mm	LOCATION		WRX STI
<p>15: Install muffer gaskets (E) onto muffer tubes protruding from flanges.  16: Align the muffer flanges with the rear exhaust pipe flanges and loosely tighten the 6 bolts (F) and 6 locking nuts (G), until flanges make contact.</p>					

TOOLS			LOCATION		WRX STI
<p>17: Center tips evenly within the rear bumper fascia. Use the narrowest part of the fascia towards the front of the vehicle as your reference. See arrows.</p>					

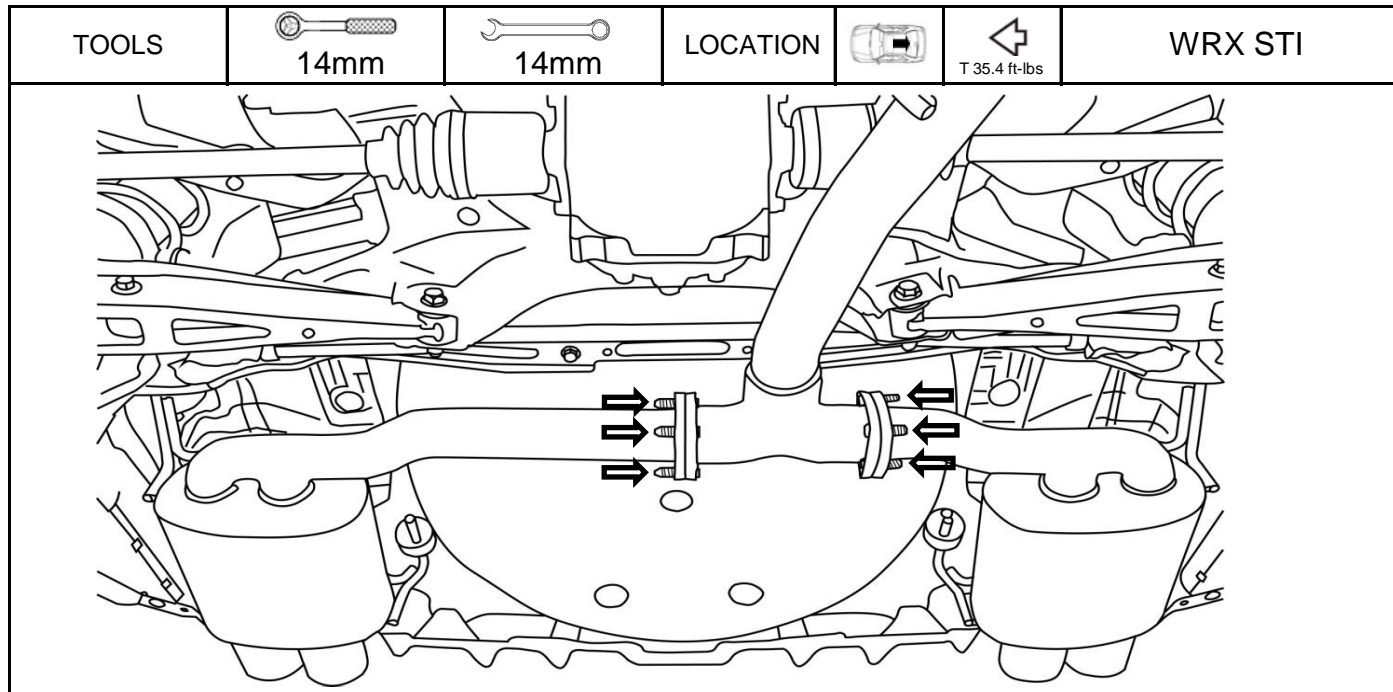

18: Torque nuts to 35.4 ft-lbs (48 N·m). Recheck tip position and adjust if necessary.

19: Refer to Disclaimer and Care instructions prior to starting the vehicle. Any contaminants left on the exhaust systems such as grease, oils, and/or fingerprints may result in permanent staining. Store the Disclaimer and Care Sheet in the vehicle's glove compartment.

### ATTENTION

AFTER INSTALLATION RECHECK ALL FASTENER TORQUE VALUES.

LIGHT GRAY SMOKE MAY BE VISIBLE DURING THE FIRST FEW MILES OF OPERATION AS THE RESIDUAL PROTECTIVE OIL IS BURNED AWAY. THIS IS EXPECTED AND NORMAL.





**SUBARU**

NUMÉRO DE PIÈCE : D441SVA000

INSTRUCTIONS D'INSTALLATION

DESCRIPTION :  
SYSTÈME D'ÉCHAPPEMENT HAUTE PERFORMANCE  
WRX STI

A

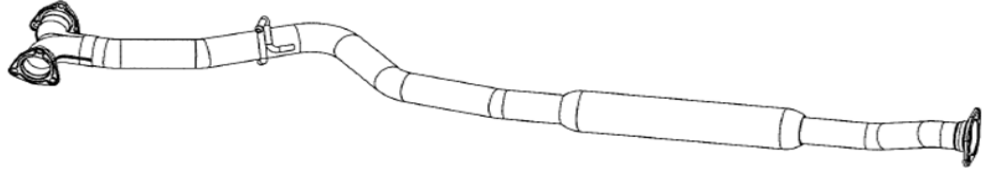

TUYAU D'ÉCHAPPEMENT ARRIÈRE

B

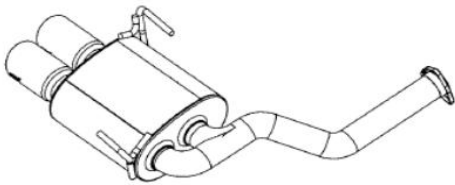

SILENCIEUX DROIT

C

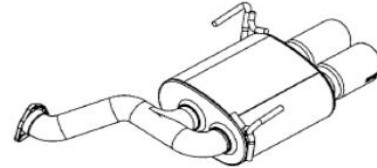

SILENCIEUX GAUCHE

D



JOINT D'ÉTANCHÉITÉ

E



JOINT D'ÉTANCHÉITÉ DE  
SILENCIEUX

F



BOULON

G



ÉCROU DE BLOCAGE

H



**AVIS DE NON-RESPONSABILITÉ ET DIRECTIVES D'ENTRETIEN**

TROUSSE DE RÉPARATION, N° DE PIÈCE D441SVA040 : CONTIENT LES ARTICLES D,E,F,G,H

OUTILS REQUIS :

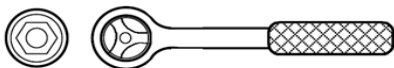

DOUILLE LONGUE ET ROCHET DE 14 mm et 12 mm



CLÉ DYNAMOMÉTRIQUE



RALLONGE



CLÉ À DOUILLE DE 14 mm et 12 mm

NUMÉRO DE PIÈCE :  
D441SVA000

VERSION 01  
01

1/28/2014

SUBARU OF AMERICA

PAGE  
1/8

## SIGNIFICATION DES SYMBOLES

: Retirer

: Installer

: Déconnecter

: Connecter

 : Emplacement de l'attache  
ou de la vis

: Procédé manuel

: Couple de serrage

: Desserrer

: Jeter

: Réutiliser

OUTILS			EMPLACEMENT			WRX STI
<p>1. Soulevez le véhicule. <b>MISE EN GARDE</b> : Les composants du véhicule sont très chauds après la conduite. Ne touchez pas aux composants jusqu'à ce que le véhicule ait refroidi.</p> <p>2. Enlevez et jetez les boulons et les écrous fixant le tuyau d'échappement arrière aux silencieux.</p>						

OUTILS			EMPLACEMENT			WRX STI
--------	--	--	-------------	--	--	---------

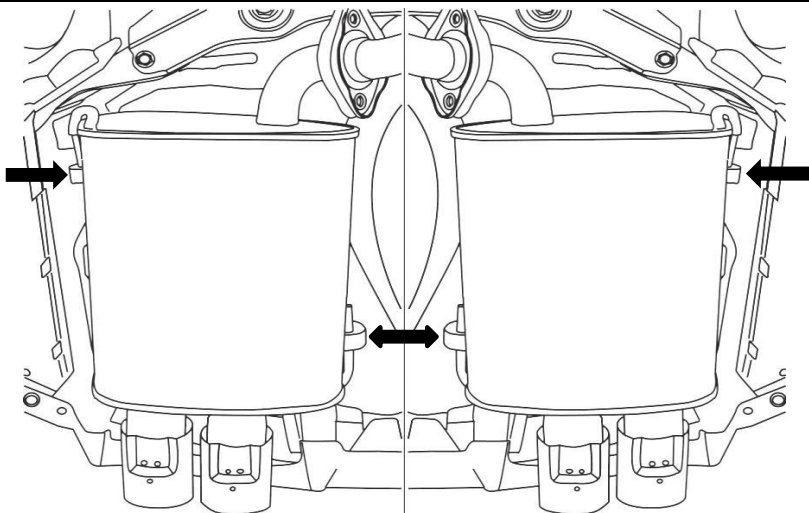

3. Appliquez une couche de lubrifiant en aérosol sur la zone de contact des supports en caoutchouc de l'échappement.
4. Déposez les silencieux des supports en caoutchouc de l'échappement. MISE EN GARDE : Prenez garde de ne pas échapper les silencieux lors de la dépose.

OUTILS	14 mm	12 mm	EMPLACEMENT	RÉUTILISER		WRX STI
--------	-------	-------	-------------	------------	--	---------

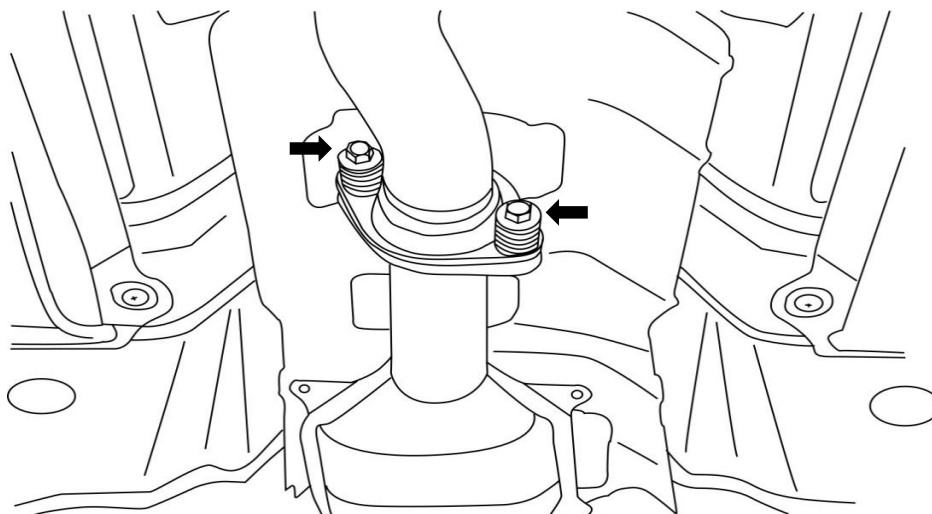

5. Retirez les boulons, ressorts et écrous du tuyau d'échappement arrière et séparez-les du tuyau du convertisseur catalytique. Jetez le joint d'étanchéité. NE PAS réutiliser le joint d'étanchéité.

OUTILS			EMPLACEMENT			WRX STI
--------	--	--	-------------	--	--	---------

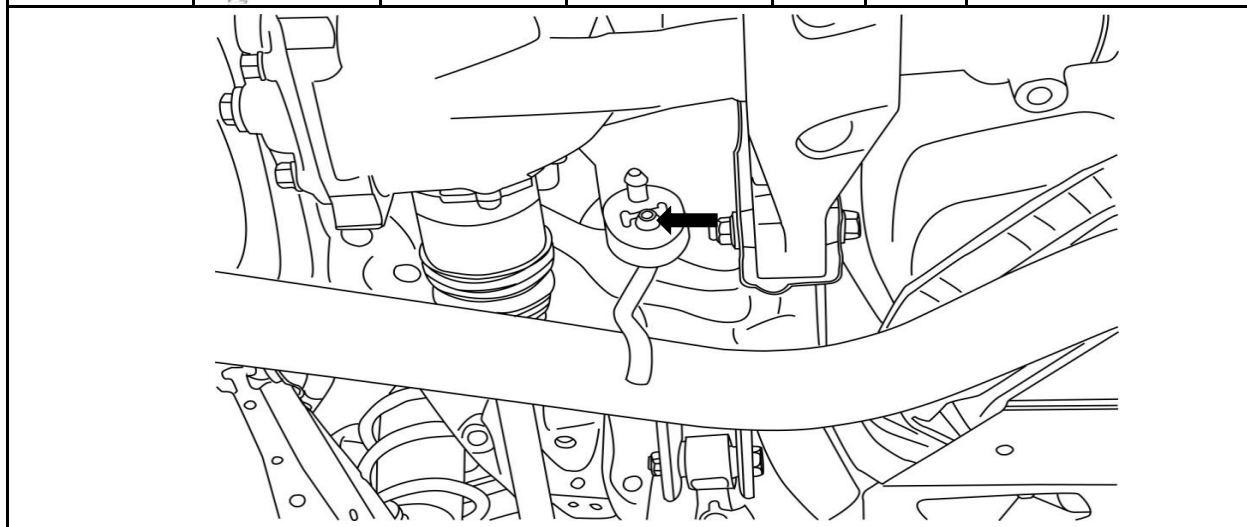





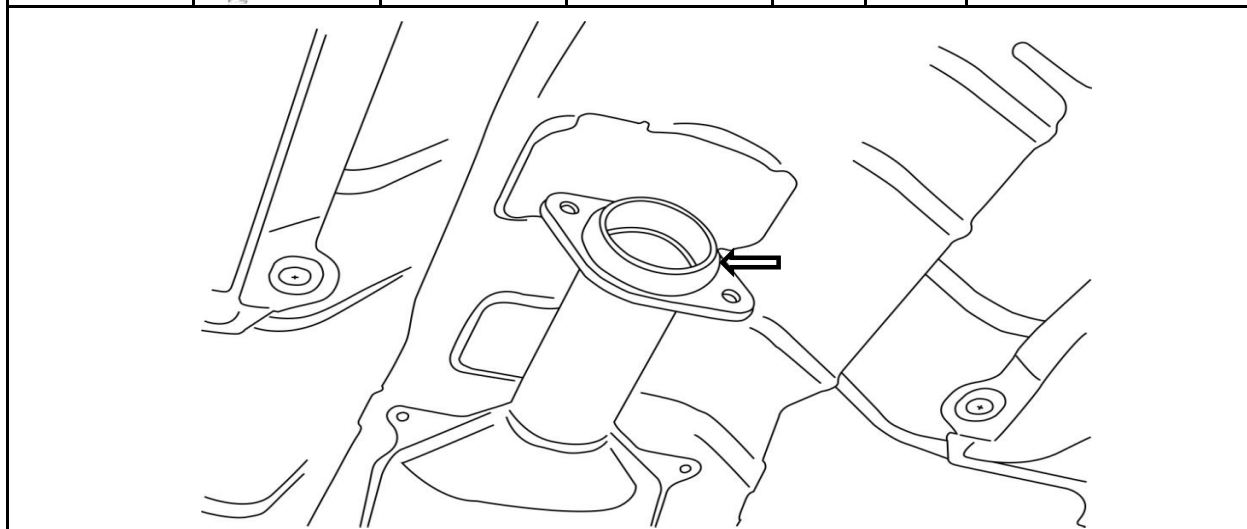

6. Appliquez une couche de lubrifiant en aérosol sur la zone de contact des supports en caoutchouc de l'échappement.
7. Déposez le tuyau d'échappement arrière du support en caoutchouc de l'échappement. MISE EN GARDE : Prenez garde de ne pas échapper le tuyau d'échappement arrière lors de la dépose.

OUTILS			EMPLACEMENT			WRX STI
--------	--	--	-------------	--	--	---------

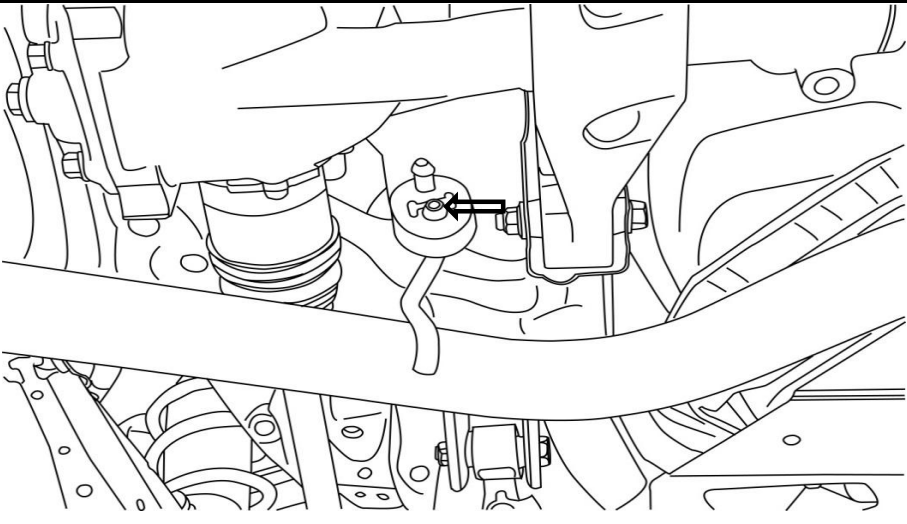

8. Posez le joint d'étanchéité neuf (D) sur le tuyau du convertisseur catalytique.

OUTILS		EMPLACEMENT			WRX STI
					
<p>9. Posez le tuyau d'échappement arrière neuf (A) dans le support en caoutchouc de l'échappement.                      10. Enlevez le lubrifiant appliqué sur le support en caoutchouc de l'échappement lors de la dépose ou de l'installation.</p>					

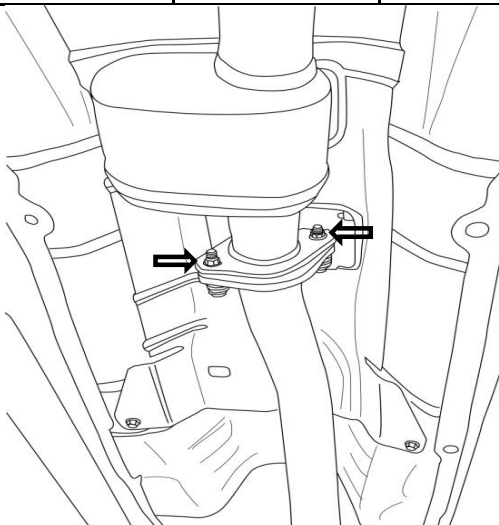
OUTILS	 14 mm	 12 mm	EMPLACEMENT	 13,3 lb-pi	WRX STI
					
<p>11. Raccordez le tuyau d'échappement arrière (A) neuf au tuyau du convertisseur catalytique avec les boulons, ressorts et écrous retirés à l'étape 5. Serrez les écrous au couple de 13,3 lb-pi (18 N.m).</p>					

OUTILS			EMPLACEMENT		←	WRX STI
--------	---	--	-------------	--	---	---------

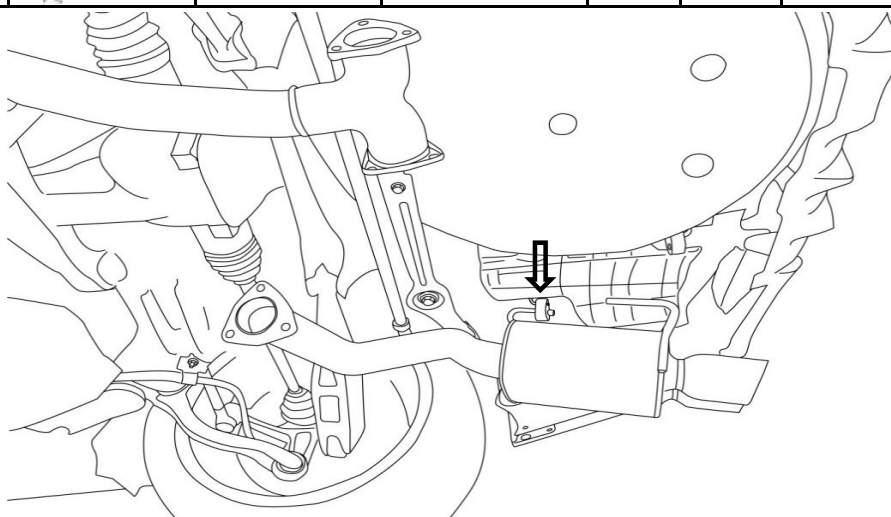

12. Accrochez le silencieux (B) neuf sur le support d'échappement extérieur.

OUTILS			EMPLACEMENT		←	WRX STI
--------	---	--	-------------	--	---	---------

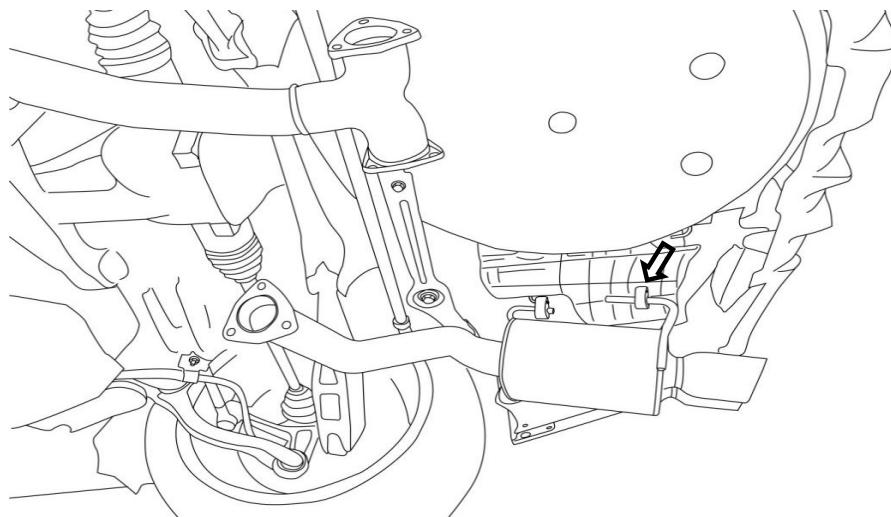

13. Transférez le support d'échappement intérieur du véhicule au silencieux. Ensuite, réinstallez le silencieux et le support extérieur sur le véhicule.

14. Silencieux droit montré, répétez les étapes 12 et 13 pour le silencieux gauche.

OUTILS	 14 mm	 14 mm	EMPLACEMENT		WRX STI
<p>15. Installez les joints d'étanchéité de silencieux (E) sur les tuyaux de silencieux en saillie des brides.</p> <p>16. Alignez les brides du silencieux avec les brides du tuyau d'échappement arrière et serrez légèrement les 6 boulons (F) et les 6 écrous de blocage (G) jusqu'à ce que les brides se touchent.</p> <p>15. Installez les joints d'étanchéité de silencieux (E) sur les tuyaux de silencieux en saillie des brides.</p> <p>16. Alignez les brides du silencieux avec les brides du tuyau d'échappement arrière et serrez légèrement les 6 boulons (F) et les 6 écrous de blocage (G) jusqu'à ce que les brides se touchent.</p>					

OUTILS		EMPLACEMENT		WRX STI
<p>17. Centrez les embouts également à l'intérieur du carénage arrière. Servez-vous de la partie la plus étroite du carénage vers l'avant du véhicule comme point de référence. Voir les flèches.</p>				

OUTILS	 14 mm	 14 mm	EMPLACEMENT	 35,4 lb-pi	WRX STI
--------	---	---	-------------	---	---------

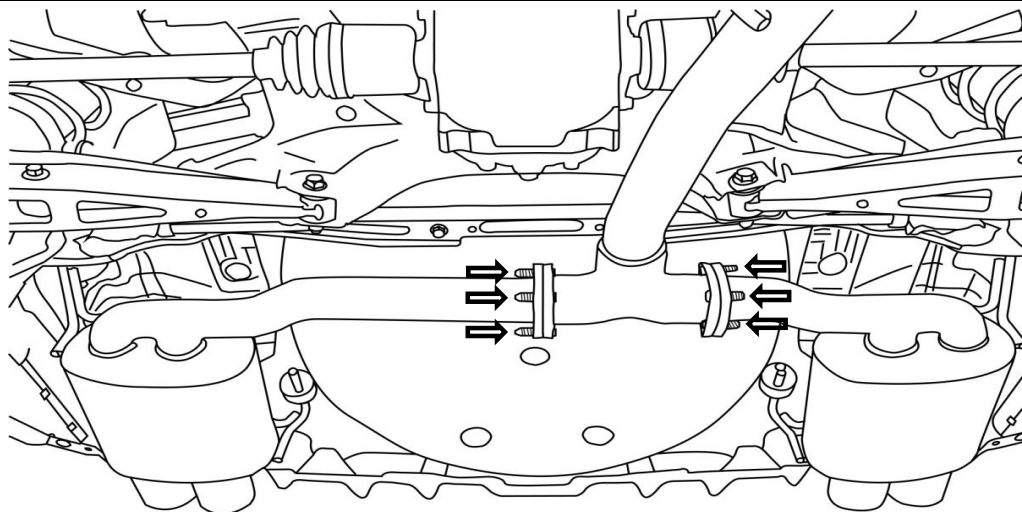

18. Serrez les écrous au couple de 35,4 lb-pi (48 N.m). Vérifiez de nouveau la position de l'embout et ajustez au besoin.

19. Reportez-vous à l'avis de non-responsabilité et aux directives d'entretien avant de démarrer le véhicule. Les contaminants qui restent sur les systèmes d'échappement, par exemple, la graisse, l'huile ou les empreintes, laisseront des taches permanentes. Rangez le document Avis de non-responsabilité et directives d'entretien dans la boîte à gants du véhicule.

**ATTENTION**

APRÈS L'INSTALLATION, VÉRIFIEZ DE NOUVEAU LE COUPLE DE SERRAGE DE TOUTES LES FIXATIONS.

UNE FUMÉE GRIS PÂLE PEUT ÊTRE VISIBLE PENDANT LES PREMIERS KILOMÈTRES DE FONCTIONNEMENT, ALORS QUE L'HUILE PROTECTRICE RÉSIDUELLE EST BRÛLÉE. CELA EST NORMAL.